

ENERGY HARVESTING FROM TRAIN VIBRATIONS

M. Ghandchi Tehrani*¹, G. Gatti², M. J. Brennan³, D. J. Thompson¹

¹University of Southampton, Institute of Sound and Vibration Research
m.gandchi-tehrani@soton.ac.uk, djt@isvr.soton.ac.uk

² University of Calabria
gianluca.gatti@unical.it

³Departamento de Engenharia Mecânica, UNESP Ilha Solteira
mjbrennan0@btinternet.com

Keywords: Energy Harvesting, Linear Oscillator

Abstract. *An investigation is carried out into how much energy can be harvested from the vibration of a passing train using a mechanical oscillator. The harvested energy could be used, for example, to charge sensors mounted on the railway track for structural health monitoring. The dominant frequencies due to a passing train are determined for a specific train and speed from a recorded acceleration time-history. Using a simple model of an oscillator, the total energy harvested during the passage of one train is calculated. The stiffness, and hence the tuning frequency of the device, is varied in simulations to determine the optimum frequency at which to tune the device for a constant value of mass and damping in the device. Further simulations are conducted to investigate the power that could be harvested from multiple oscillators tuned at several dominant frequencies, and their performances are analysed and compared. The constraint for maximum relative displacement is considered for each harvester, which is adopted to ensure that the amplitude of the oscillation does not exceed the physical size of the device.*

1 INTRODUCTION

Over the last decade, significant research activity has been devoted to energy harvesting from ambient mechanical vibration. Most of the research activity has been motivated by the need to power wireless intelligence systems embedded within smart structures [1, 2].

Piezo-electric harvesters have received considerable attention for small-scale applications [3, 4]. Large-scale energy harvesting from vibrating structures has also recently been shown to be a viable source of renewable energy. The use of electromagnetic transducers has been investigated to extract power from vibration in automotive suspensions [5], railway systems [6], wave excitation of offshore structures [7], and wind excitation of buildings [8]. The available power from such applications has been estimated at the watt- to kilowatt-scale. A British company Perpetuum Ltd [9] developed a tuned vibration harvester, which can harvest 10-50 mW of energy. The French National Railway SNCF [10] also did some investigations for harvesting energy for low power wireless sensors. Mian [11] generated power by placing an electromagnetic coil near the rail, so that when the train wheel passes by, the magnetic flux in the coil changes, thereby generating electricity. Nelson et al [12] mounted piezoelectric films on the bottom of a rail and harvested 1mW energy from the longitudinal strain of the bending rail. They also used an electromagnetic harvester, which was able to harvest power of 0.22 W from a loaded train passing at 11.5 mph in a field test [13]. An Israeli company, Innowattech Ltd, have developed energy harvesting piezoelectric pads to replace the conventional rail pads [14].

In order to increase the frequency bandwidth of resonant energy harvesters, various non-linear stiffness elements have been suggested [15-18]. Recently, nonlinear damping has been introduced in order to increase the dynamic range over which the vibration energy harvester can operate [19].

The aim of this paper is to determine how much energy can be harvested from track vibration using a resonant harvester, during the passage of an Inter-city 125 at a speed of 195 km/h. The harvested energy could be used, for example, to power wireless sensors for railway track monitoring. When the passing train moves over a track, the track deflects due to the load exerted by the train's bogies and therefore can excite the harvester mounted on the track. The measured acceleration on the sleeper is used as the base excitation for the linear harvester. Since, the operational frequency range of the harvester is below 25 Hz, the dynamics of the railway track are ignored.

2 TRAIN-INDUCED VIBRATIONS

In this paper a vibration signal obtained from an Inter-city125, is used. The train, which is depicted in Fig. 1a, consists of 2 diesel power cars, one at each end, with 7 passenger coaches between them. Each vehicle is supported by four wheelsets arranged in two bogies; the bogie wheelbase is 2.6 m in each case. The power cars are 17.8 m long while the trailer vehicles are 22.9 m long. The distance between bogie centres is 16.0 m for the trailer vehicles and 10.3 m for the power cars.

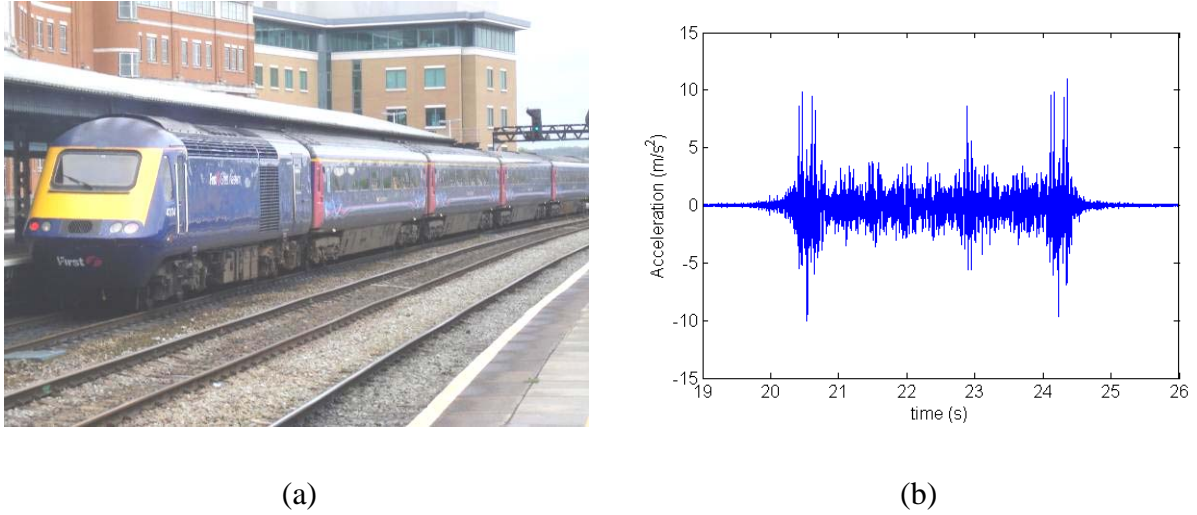

Figure 1: (a) Photograph of an Inter-city 125 train, and (b) measured acceleration on the sleeper for an Inter-city 125 passing at a speed of 195 km/h.

The measured acceleration of the sleeper during the passage of an Inter-city 125 train at a speed of 195 km/h (54.2 m/s) is shown in Fig. 1b. The measured acceleration data is integrated to obtain the vertical velocity due to a passing train and this is shown in Fig. 2a. Figure 2b shows the amplitude spectrum of the vertical velocity. In this figure the dominant frequencies, in which the most significant amount of energy can be harvested can be seen. The dominant frequencies, corresponding to the highest peaks are at about 2.4 Hz, 4.8 Hz, 7.1 Hz, 14.3 Hz, 16.6 Hz and 21.3 Hz.

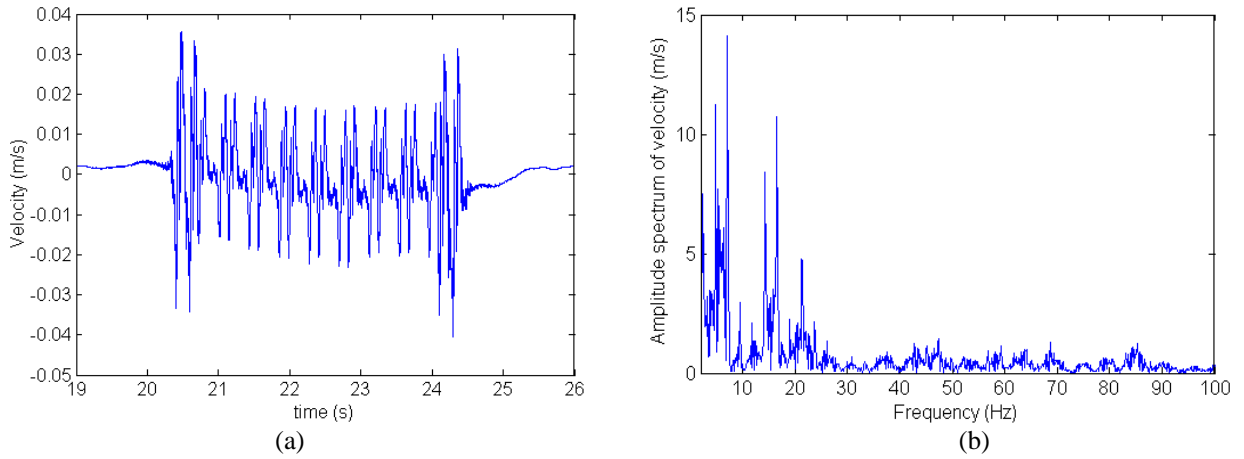

Figure 2: Velocity data derived from the experimental measurements in Fig. 1b: (a) time-history and (b) amplitude spectrum.

The vibration from a passing train consists of two components: quasi-static excitation due to the moving axle loads and dynamic excitation due to surface roughness [21]. Regarding the quasi-static excitation, Ju et al. [22] showed that the dominant frequencies from trainload vibrations are integer multiples of the train speed, V , divided by the carriage length, L , as

$$f = \frac{nV}{L}. \quad (1)$$

They also derived an approximate expression for the influence factors, which is given by

$$R_f = N_c P_{\text{axle}} \left| \sum_{k=1}^{N_w} e^{-i2n\pi S_k/L} \right| \quad (2)$$

where N_c is the number of carriages (assumed identical), P_{axle} is the load of a wheelset, N_w is the number of wheelsets in the carriage, and S_k is the distance between each wheelset and the beginning of the carriage. In the present case, for the trailer vehicles, these distances are given by 2.15 m, 4.75 m, 18.15 m and 20.75 m, with $L = 22.9$ m. The influence factors are only dependent on the ratio of the wheel locations to the carriage length, and are independent of the train speed.

Using Eq. (1), the frequency axis of the velocity spectrum in Fig. 2b is normalized by V/L , and shown in Fig. 3a for a limited range. It can be seen from Fig. 3a that the velocity peaks mostly occur at integer multiples of V/L . This confirms that the quasi-static excitation is the main source of vibration also in this case. The influence factors are determined using Eq. (2), neglecting the power cars, and are shown in Fig. 3b, for each dominant frequency. For n equal to 4, 5, 13 and 14 there is a small influence factor. This seems to be consistent with the relatively small peaks appearing in the experimental data shown in Figure 3a. Thus Figs. 3a and b are qualitatively similar. However, differences occur at higher orders since the deflection under a wheel load is not a delta function (as assumed in [22]) but forms a deflection bowl on the rail with a length of around 2 m due to the rail bending stiffness. Neglect of the power cars may also have an influence.

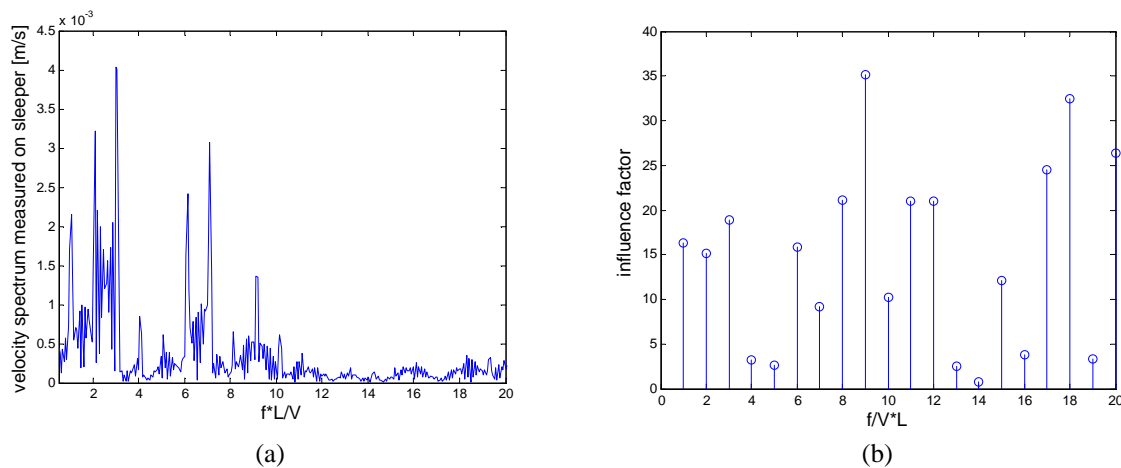

Figure 3: (a) Velocity spectrum as a function of the frequency normalized by V/L , (b) Influence factors at the normalized trainload dominant frequencies.

3 ENERGY HARVESTED FROM A LINEAR OSCILLATOR

A single degree-of-freedom system (spring-mass-damper) such as that shown in Figure 4 is considered as the energy harvester. In Fig. 4, m is the mass of the oscillator, k is the suspension stiffness, c is the viscous damper, x is the mass displacement, and y is the base displacement, which, in this case, is obtained from the measured acceleration data on the railway track. The dynamics of the track are ignored since it behaves quasi-statically as a spring within the frequency range in which the harvester is operating (below 25Hz) [21]. Thus, although the vibration was measured on the sleeper, the rail vibration is expected to be identical in this frequency range.

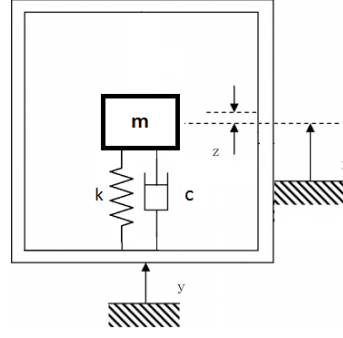

Figure 4: Linear single degree-of-freedom base excited system.

The governing dynamic equation of the system depicted in Figure 4 is given by

$$m\ddot{z} + c\dot{z} + kz = -m\ddot{y} \quad (3)$$

where z is the relative displacement between the mass of the harvester and the casing. To gain some physical insight into the important parameters that affect the amount of energy that can be harvested, steady-state harmonic excitation is first considered. The energy harvested in one cycle subject to a base excitation of $y(t) = Y \sin(\omega t)$ is given by [16],

$$E = \int_0^{2\pi/\omega} c\dot{z}^2(t) dt = cZ^2\omega\pi, \quad (4)$$

where Z is the amplitude of the relative displacement. This is related to the amplitude of the base displacement by,

$$\frac{Z}{Y} = \frac{m\omega^2}{\sqrt{(k - \omega^2 m)^2 + (c\omega)^2}}. \quad (5)$$

For a linear system with a given amount of damping, the maximum input power occurs when the system is tuned so that its natural frequency equals the excitation frequency. When the natural frequency of the harvester is tuned to the excitation frequency, and light damping is assumed, the maximum relative displacement is approximately given by

$$Z_{\max} \approx \frac{m\omega_n Y}{c}, \quad (6)$$

where $\omega_n = \sqrt{k/m}$ is the natural frequency of the oscillator. Equation (6) can be used to design a harvester such that the relative displacement does not exceed a given threshold. It can be rearranged so that the damping can be determined for a given set of design and operational parameters, by

$$c = \frac{m\omega Y}{Z_{\max}}, \quad (7)$$

Equation (7) can be substituted into Eq.(4) to give an expression for the maximum harvested energy in terms of the mass, the amplitude of the input displacement, the amplitude of the relative displacement between the mass and the housing, and the square of the excitation frequency, as

$$E = \pi m \omega^2 Y Z_{\max}. \quad (8)$$

It can thus be seen that when the harvester is excited at its natural frequency, the damping has to be adjusted to maintain the relative displacement between the mass and the base to a prescribed level. The energy harvested is then proportional to the inertial mass of the harvester, the base acceleration, $\omega^2 Y$, and the size of the device (magnitude of the relative displacement).

4 SIMULATIONS

As discussed above, the acceleration data from the train-induced vibrations is used as the base excitation. A linear harvester is considered, in which the mass is fixed at 1 kg and the damping is initially fixed at 0.5 Ns/m. The stiffness of the harvester is varied so that its natural frequency is tuned between 1 and 25 Hz with a step of 0.1429 Hz. A Simulink model was generated to calculate the instantaneous power and the total energy harvested for the passage of a single train for each natural frequency considered. A Matlab solver (ode15s), with the convergence tolerance of 10^{-6} , and a variable time step was used at every tuning frequency to obtain the instantaneous power. The total energy was then found by integrating the instantaneous power over a 7 second period. Figure 5 shows the results. It can be seen that when the harvester is tuned at the dominant frequencies corresponding to about 7.1 Hz, 14.3 Hz, 16.6 Hz and 21.3 Hz, a relatively high amount of energy can be harvested. However, the greatest amount of energy can be harvested when the device is tuned to 16.6 Hz.

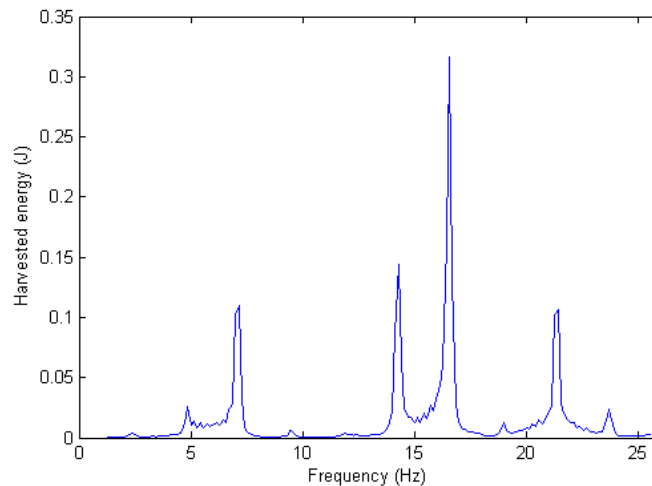

Figure 5: Energy harvested as a function of the tuning frequency of the oscillator, with $c=0.5$ Ns/m and $m=1$ kg.

Figure 6 shows the effect of varying the damping on the energy harvested for a given mass of 1 kg. By increasing the damping, the energy harvested is reduced, when the oscillator is tuned at the four most evident dominant frequencies mentioned above, as expected from Eqs. (4,5) at the natural frequency of the oscillator.

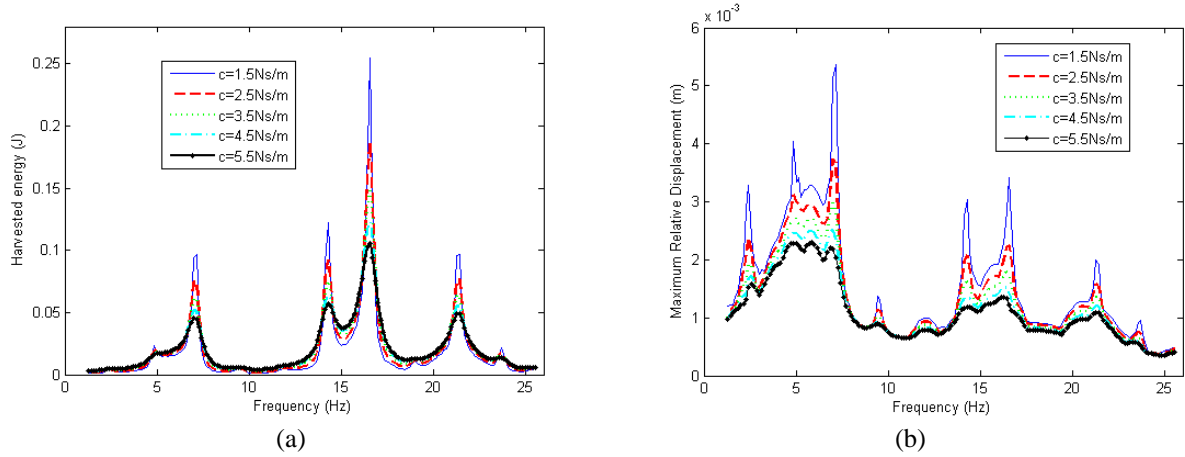

Figure 6: (a) Energy harvested and (b) maximum relative displacement as a function of the tuning frequency of the oscillator, for different values of damping and a given mass of 1 kg.

Now, the constraint of the maximum relative displacement is considered and the performance of a linear harvester is investigated at different tuning frequencies for two values of mass, 0.1 and 1 kg. An iterative approach was used to adjust the damping so that the maximum relative displacement was never greater than an operational limit, which here, was selected to be $Z_{\max} = 1.5\text{ mm}$. A minimum damping value of 0.01 Ns/m was considered as the initial value. The maximum damping did not exceed the critical value of damping given in Eq. (7). The damping values that result in the maximum relative displacement when the device is tuned to different natural frequencies are shown in Fig. 7a. The corresponding damping ratios are shown in Fig. 7b. It can be seen that the required damping is much higher for a tuned frequency of 7.1 Hz compared to 16.6 Hz. It can also be seen that the damping is approximately proportional to the size of the mass.

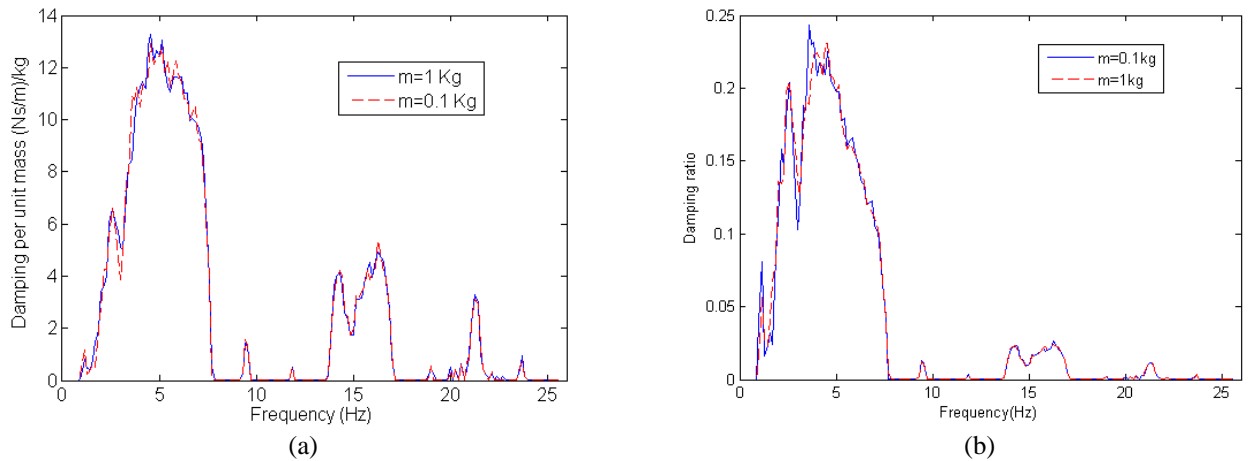

Figure 7: (a) Damping and (b) damping ratio adjusted to satisfy the maximum relative displacement constraint for two values of inertial mass

The maximum relative displacement is shown in Fig. 8(a), which clearly shows that the constraint is satisfied. The energy harvested is then found by integrating the instantaneous

power from 0 to 7 s for every tuning frequency of the oscillator. This is illustrated in Fig. 8 (b).

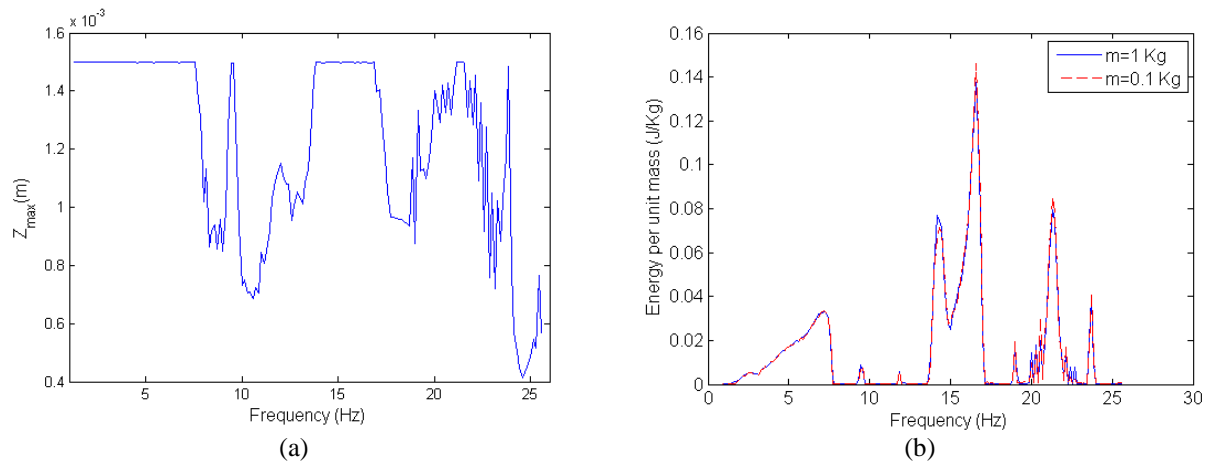

Figure 8: (a) maximum relative displacement and (b) energy harvested in 7s by a single degree of freedom oscillator, as a function of its tuning frequency.

The harvested energy per unit mass, which is shown in Fig. 8(b), is clearly a maximum when the harvester is tuned at about 16.6 Hz. The corresponding damping ratio for this harvester is 0.02, which is much smaller than for other frequencies as was seen in Fig. 7.

5 CONCLUSIONS

An investigation has been carried out into how much energy can be harvested from the vibration of a passing train, using a mechanical oscillator. Using the measured acceleration time-history of a track due to a specific train at a particular speed, the total energy harvested for the passage of a train has been calculated for a range of devices with different natural frequencies. The stiffness, and hence the tuning frequency of the device, was varied in simulations to determine the optimum frequency at which to tune the device for a fixed value of mass and damping in the device. So that the amplitude of the oscillation does not exceed the physical limit of the device a constraint was put on the relative displacement. With this constraint, it was found that the greatest energy was harvested at a frequency of 16.6 Hz even though this was not the dominant frequency in the velocity spectrum. However, a slight change in the tuning frequency of the harvester at 16.6 Hz, may result in the harvested power being much less. In the limited investigation carried out in this paper it has been found that in ideal conditions a single device can harvest a maximum of about 0.15 J/kg.

REFERENCES

- [1] S. Roundy, P. K. Wright, J. Rabaey, A study of low level vibrations as a power source for wireless sensor nodes, *Journal of Computer Communications*, **26**,1131-1144,2002.
- [2] C. Knight, J. Davidson, S. Behrens, Energy options for wireless sensor nodes, *Sensors*, **8** 8037–8066, 2008.
- [3] H. A. Sodano, D. J. Inman, G. Park, Comparison of piezoelectric energy harvesting devices for recharging batteries, *Journal of Intelligent Material Systems*, **16**,799-807, 2005.

- [4] Y. C. Shu, I. C. Lien, Analysis of power output for piezoelectric energy harvesting systems, *Smart Materials and Structures*, **15**,1499–1512, 2006.
- [5] L. Zuo, B. Scully, J. Shestani, Y. Zhou, Design and characterization of an electromagnetic energy harvester for vehicle suspensions, *Smart Materials and Structures*,**19** (045003), 2010.
- [6] C. Nagode , M. Ahmadian, S.Taheri , Effective energy harvesting devices for rail road applications, *Proceedings of the SPIE Conference on Smart Structures/NDE*, **7643**, San Diego, CA, 2010.
- [7] S. M. Lattanzio, J. T. Scruggs, Maximum power generation of a wave energy converter in a stochastic environment, *Proceedings of the IEEE International Conference on Control Applications*, Denver, CO, 1125–1130, 2011.
- [8] T. Ni, L. Zuo, A. Kareem, Assessment of energy potential and vibration mitigation of regenerative tuned mass dampers on wind excited tall buildings, *Proceedings of the ASME International Design Engineering Technical Conferences*, Washington, DC, 2011.
- [9] Perpetuum Ltd, Southampton, UK, www.perpetuum.com
- [10] O. Gatin and B. Lhenoret, WSN and Energy harvesting for railway applications, presentation at Energy harvesting and Storage USA, Denver, CO, 2009.
- [11] Z.F. Mian, 2009, Wireless railroad monitoring, US patent 12/493,789.
- [12] C.A. Nelson, S. R. Platt, D. Albrecht, V. Kamarajugadda, and M. Fateh, Power harvesting for rail road track health monitoring using piezoelectric and inductive devices, *Proc. of the SPIE: Active and Passive Smart Structures and Integrated Systems*, **6928**(1), 2008.
- [13] C.A. Nelson, S. R. Platt, S. E. Hansen, M. Fateh, Power harvesting for railroad track safety enhancement using vertical track displacement, *Proc. of the SPIE: Active and Passive Smart Structures and Integrated Systems*, **7288**, 2009.
- [14] Innowattech Ltd, Technion City, Haifa, Israel.
- [15] B. P. Mann and N. Sims, Using nonlinearity to improve the performance of vibration based energy harvesting devices, *7th European Conference on Structural Dynamics*, Southampton, July 2008.
- [16] R. Ramlan, M.J. Brennan, B.R. Mace and I. Kovacic, Potential benefits of a non-linear stiffness in an energy harvesting device, *Nonlinear Dynamics*, **59**, 545-558, 2010.
- [17] B. P. Mann and N. D. Sims. Energy harvesting from the nonlinear oscillations of magnetic levitation, *Journal of Sound and Vibration*, **319**(1-2), 515–530, 2009.
- [18] F. Cottone, H. Vocca, and L. Gammaitoni. Nonlinear energy harvesting. *Physical Review Letters*, **102**(8), 2009.
- [19] A. Erturk and D.J. Inman. Broadband piezoelectric power generation on high-energy orbits of the bistable Duffing oscillator with electromechanical coupling. *Journal of Sound and Vibration*, **330**(10) , 2339–2353, 2011.
- [20] M. Ghandchi Tehrani and S. Elliott, Energy harvesting using nonlinear control, Conference on Acoustics, AIA-DAGA 2013, Merano, Italy, March 2013.
- [21] D. Thompson, Railway Noise and Vibration, Mechanics, Modelling and Means of Control, Elsevier, 2009.
- [22] S. Ju, H. Ling, J. Huang, Dominant frequencies of train-induced vibrations, *Journal of Sound and Vibration*, **319**, 247-259. 2009.